

# Cylinders to AFNOR NF E49-001 (ex CNOMO) standard

# series CX

## DESCRIPTION

Cylinders series "CX" comply with AFNOR NF E49-001 (ex CNOMO) standard and so they result interchangeable.  
Cylinders series "CX" with magnetic piston type can be supplied with magnetic sensors.



1

## TECHNICAL DATA

Operating pressure	1 ÷ 10 bar
Working temperature	0 ÷ +80 °C (-20 °C with dry air) 0 ÷ +150 °C with seals for high temperatures (-20 °C with dry air)
Fluid	Filtered, unlubricated or continuous lubricated compressed air
Versions	Double acting; Single acting front spring; Single acting rear spring; Through rod; Double push tandem; Double stroke tandem; Opposed tandem
Bore	Ø 32, 40, 50, 63, 80, 100, 125, 160, 200
Port size	Ø 32 = G 1/8 Ø 40 - 50 = G 1/4 Ø 63 - 80 = G 3/8 Ø 100 - 125 = G 1/2 Ø 160 - 200 = G 3/4
Standard strokes (mm)	25, 50, 75, 100, 125, 150, 200, 250, 300, 350, 400, 500, 600, 700, 800, 900, 1000
Decelerators length	Ø 32 40 50 63 80 100 125 160 200 mm 25 30 30 35 35 40 40 50 50
Maximum strokes (mm)	Ø 32 ÷ 200 = 3000
Max. strokes single acting (mm)	Ø 32 ÷ 100 = 50

## MATERIALS

End caps	Anodized aluminium alloy
Cylinder barrel	Extruded tube, anodized aluminium alloy
Tie rods, tie and rod nuts	Steel Stainless steel (supplied upon request for tie rods and tie nuts)
Piston rod	C45 chromium-plated steel AISI 303 rolled stainless steel
Piston rod bearing	Bronze-iron 20%, sintered, self-lubricating
Decelerators ogives	Aluminium alloy
Piston	NBR rubber block (supplied with and without magnet) Viton® (supplied only with non-magnetic piston type)
Seals	NBR rubber Viton®

## ORDER KEY

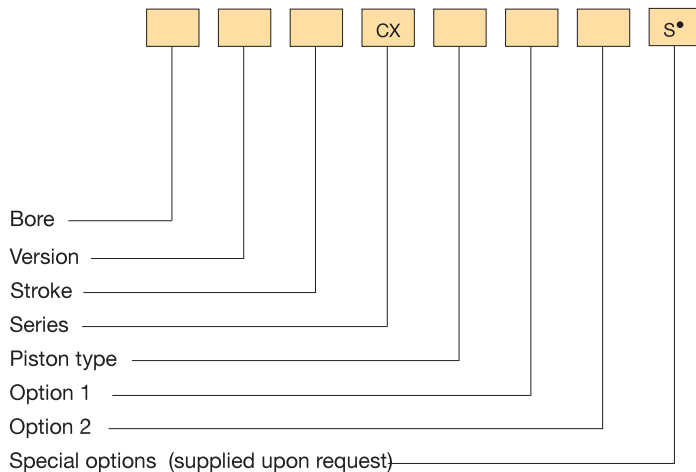

P.S.: *Magnetic sensors* FM 100 - FM157 - FM158 (see chapter magnetic sensors from page 1.93)  
• See technical data on page 0.12

## VERSION

/	Double acting	T	Double push tandem
S	Single acting front spring	P	Double stroke tandem
Y	Single acting rear spring	V	Opposed tandem
R	Through rod		

## PISTON TYPE

Non-magnetic /FM Magnetic

## OPTION 1

1	Stainless steel piston rod and rod nut	3	Stainless steel piston rod and rod nut and seals for high temperatures*
2	Seals for high temperatures**		

## OPTION 2

4	Brass cylinder barrel**	6	Inner chromium-plated steel cylinder barrel**
---	-------------------------	---	---

\* Supplied only with non-magnetic piston type  
\*\* Supplied from Ø 32 to Ø 100

## ORDER EXAMPLES

Cylinder Ø50, double acting, 100 mm stroke, non-magnetic piston type 50/100 CX

Cylinder Ø63, through rod, 150 mm stroke, magnetic piston type, stainless steel piston rod 63R150 CX/FM1

Cylinder Ø80, double push tandem, 50 mm stroke, magnetic piston type 80T50 CX/FM

Cylinder Ø80, double stroke tandem, 50 mm stroke 1 + 100 mm stroke 2, magnetic piston type 80P50+100 CX/FM

Cylinder Ø80, opposed tandem, 50 mm stroke 1 + 50 mm stroke 2, magnetic piston type, brass cylinder barrel 80V50+50 CX/FM4

## SPARE PARTS

SEALS KIT		
Non-magnetic piston type	NBR Through rod, NBR For high temperatures Through rod, for high temperatures	Ø/SG/CX Ø/SG/R/CX Ø/SG/CX2 Ø/SG/R/CX2
Magnetic piston type	NBR Through rod, NBR	Ø/SG/CX/FM Ø/SG/R/CX/FM

### CX BASIC CYLINDER

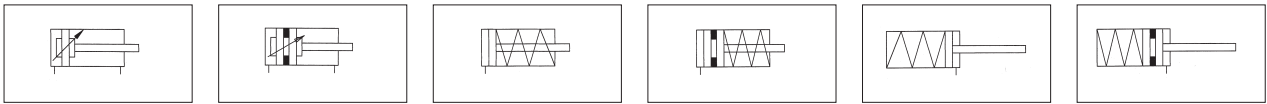
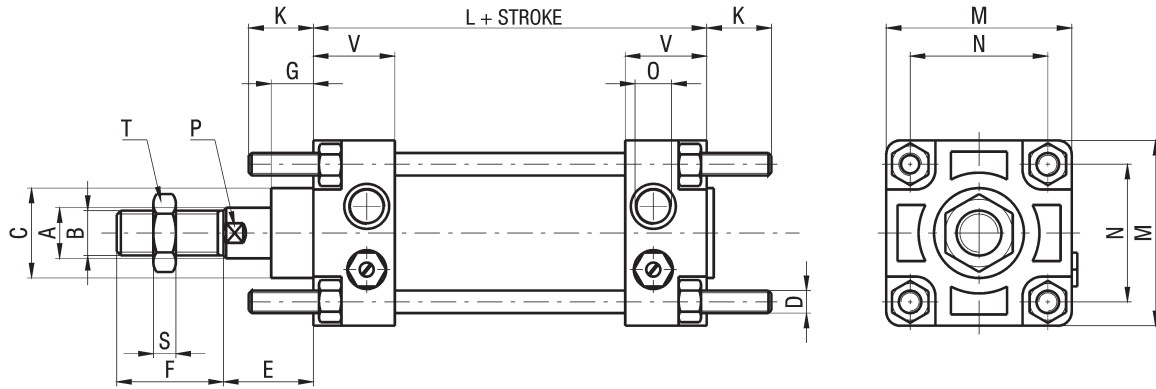

P.S.: Rod nut supplied as standard

### DIMENSIONS AND WEIGHTS BASIC CYLINDER

Ø	A	B	C	D	E	F	G	H	K	L	L1	M	N	O	P	R	S	T	V	WEIGHT (g)	INCREMENT (g) every 10 mm
32	12	M10	25	M6	25	20	15	134	17	80	90	45	33	G 1/8	10	7	5	17	26	482	23
40	18	M16x1,5	32	M6	34	36	15	191	17	110	129	52	40	G 1/4	16	7	8	24	29	907	35
50	18	M16x1,5	32	M8	34	36	15	191	23	110	129	65	49	G 1/4	16	7	8	24	29	1170	46
63	22	M20x1,5	45	M8	39	46	20	216	23	125	143	75	59	G 3/8	20	9	10	30	34	1817	59
80	22	M20x1,5	45	M10	39	46	20	215	28	125	143	95	75	G 3/8	20	9	10	30	35	2680	66
100	30	M27x2	55	M10	47	63	20	251	28	145	164	115	90	G 1/2	27	9	13,5	41	39	4422	93
125	30	M27x2	55	M12	47	63	20	248	34	145	164	140	110	G 1/2	27	9	13,5	41	42	6630	110
160	40	M36x2	65	M16	50	85	25	310	42	180	200	180	140	G 3/4	36	13	18	55	50	13820	210
200	40	M36x2	65	M16	50	85	25	310	42	180	200	220	175	G 3/4	36	13	18	55	50	18840	290

### THROUGH ROD

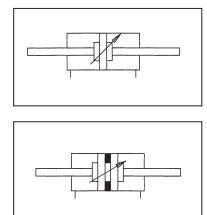
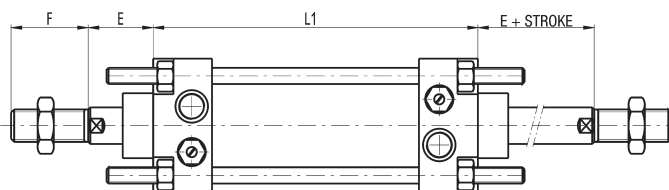

P.S.: Rod nuts supplied as standard

DOUBLE PUSH TANDEM

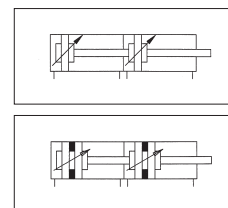
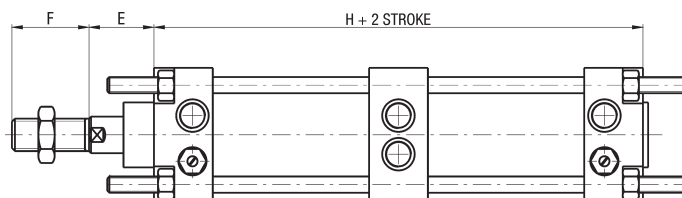

P.S.: Rod nut supplied as standard

DOUBLE STROKE TANDEM

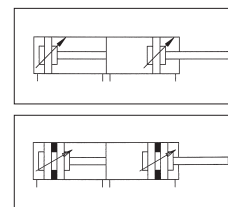
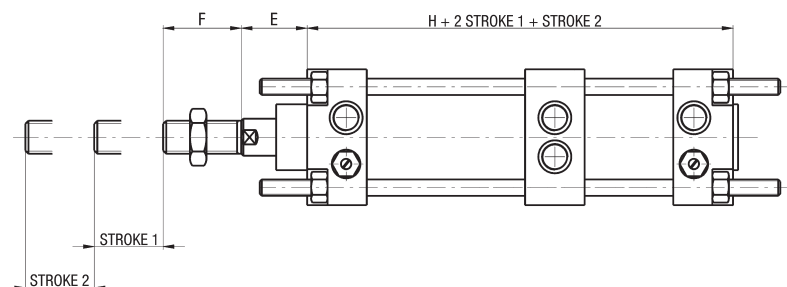

P.S.: Rod nut supplied as standard

OPPOSED TANDEM

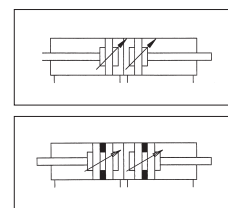
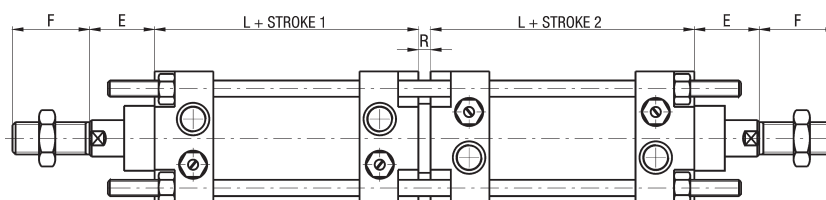

P.S.: Rod nuts supplied as standard

1

### FLANGE - STEEL - CX/F Ø

Ø	A	B	D H13	E	G	LE	LF
32	68	80	9	33	8	17	113
40	78	90	9	40	8	26	152
50	94	110	11	49	10	24	154
63	104	120	11	59	10	29	174
80	130	150	14	75	12	27	176
100	150	170	14	90	12	35	204
125	180	205	18	110	16	31	208
160	228	260	22	140	20	30	250
200	268	300	22	170	20	30	250

Ø	M	WEIGHT (g)
32	45	158
40	52	206
50	65	424
63	75	504
80	95	1046
100	115	1480
125	140	3000
160	180	6300
200	220	9300

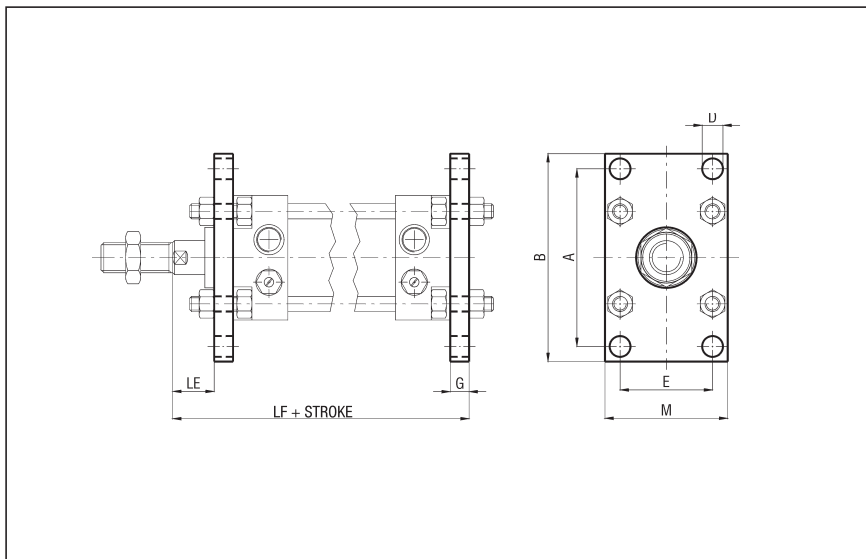

### HIGH FOOT - ALUMINIUM - CX/P Ø

Ø	A	D H13	F	G	H	LA	LW
32	28	9	32	8	35	134	132
40	36	9	36	8	35	164	171
50	45	11	45	10	45	180	179
63	55	11	50	10	45	195	199
80	70	14	63	12	55	211	207
100	90	14	73	12	55	231	235
125	100	18	91	16	68	249	244
160	130	22	115	20	82	304	292
200	170	22	135	20	92	304	292

Ø	M	O	WEIGHT (g)
32	45	27	54
40	52	27	70
50	65	35	150
63	75	35	170
80	95	43	354
100	115	43	470
125	140	52	918
160	180	62	2300
200	220	62	3450

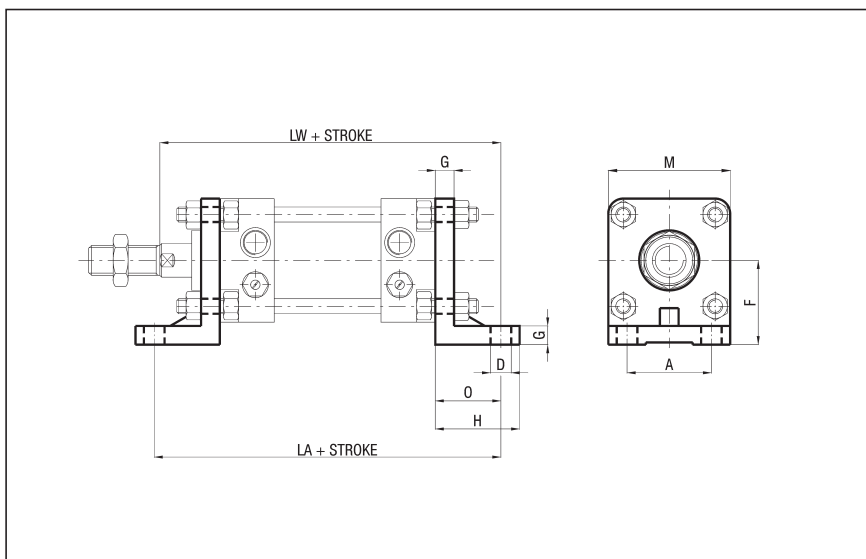

### LARGE HIGH FOOT - ALUMINIUM - CX/PL Ø

Ø	A	B	D H13	F	G	H	LC
32	65	82	9	32	8	35	116
40	72	90	9	36	8	35	146
50	90	110	11	45	10	45	154
63	100	120	11	50	10	45	169
80	126	154	14	63	12	55	181
100	148	180	14	73	12	55	201
125	180	216	18	91	16	67,5	209
160	230	275	22	115	20	80	260
200	270	318	22	135	20	80	260

Ø	LD	LP	LQ	M	O	P	WEIGHT (g)
32	60	95	123	45	18	54,5	76
40	90	134	162	52	18	62	90
50	86	132	166	65	22	77,5	188
63	101	152	186	75	22	87,5	206
80	93	148	192	95	28	110	410
100	113	176	220	115	28	130	576
125	113	176	224	140	32	161	1058
160	140	210	270	180	40	206	2350
200	140	210	270	220	40	246	3100

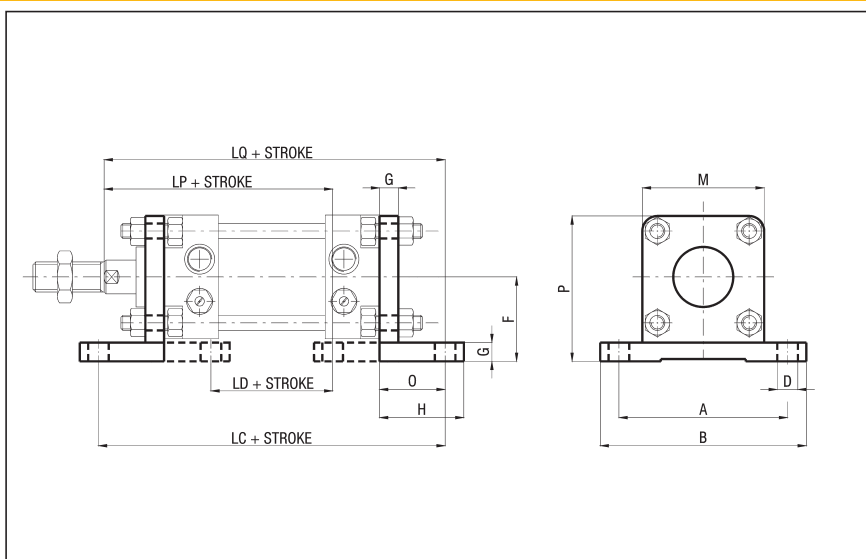

LOW FOOT - STEEL - CX/PB Ø

Ø	A	D	E	F	H	LA	LW
32	28	45	15,5	32	35	134	132
40	36	52	16	36	36	164	171
50	45	65	20,5	45	45	180	179
63	55	75	20,5	50	45	195	199
80	70	95	25,5	63	55	211	207
100	90	115	27	73	56	231	235
125	100	140	36	91	70	249	244
160	130	180	45	115	75	304	292
200	170	220	47	135	100	304	292

Ø	M	O	S	WEIGHT (g)
32	4,5	27	4	66
40	4,5	27	4	78
50	5,5	35	5	168
63	5,5	35	5	190
80	7	43	6	382
100	7	43	6	452
125	9	52	8	1090
160	11	62	10	1180
200	11	62	12	3450

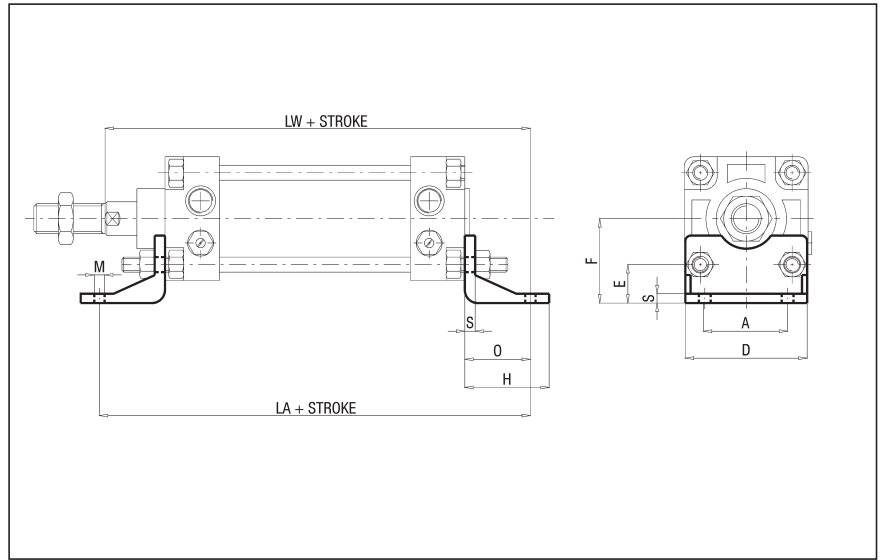

FEMALE HINGE - ALUMINIUM - CX/CF Ø

Ø	G	K	LY	M	O	R	S
32	8	18	123	45	26	8	8
40	8	24	168	52	33	12	12
50	10	26	170	65	33	12	12
63	10	30	194	75	47	16	16
80	12	32	196	95	47	16	16
100	12	37	229	115	57	20	20
125	16	41	233	140	57	21	20
160	20	55	285	180	72	25	25
200	20	55	285	220	72	25	25

Ø	WEIGHT (g)
32	38
40	58
50	118
63	146
80	324
100	492
125	978
160	1872
200	2800

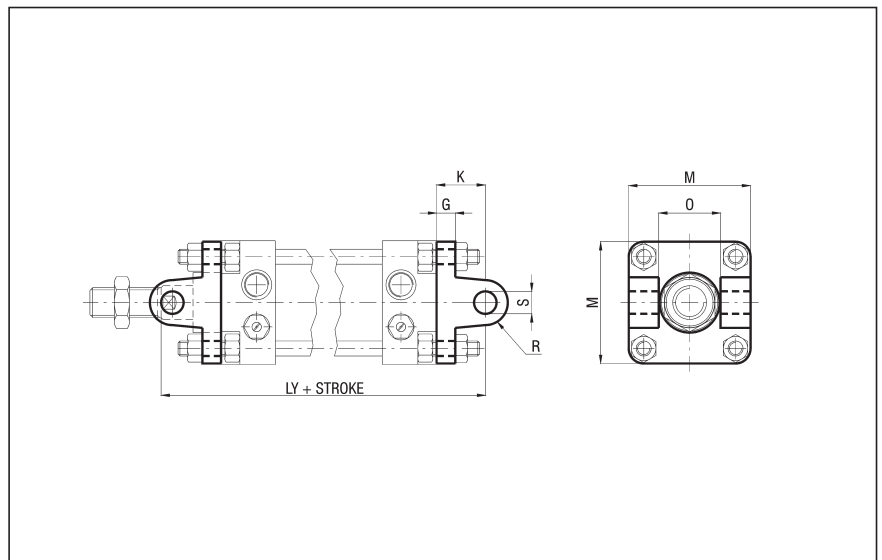

PIVOT FOR REAR FEMALE HINGE - STEEL - CX/SEC Ø

Ø	EK	EL	BU	WEIGHT (g)
32	8	46	53	21
40	12	53	60	52
50	12	66	73	64
63	16	76	83	130
80	16	96	103	160
100	20	117	124	304
125	20	142	149	364
160	25	182	189	720
200	25	222	229	872

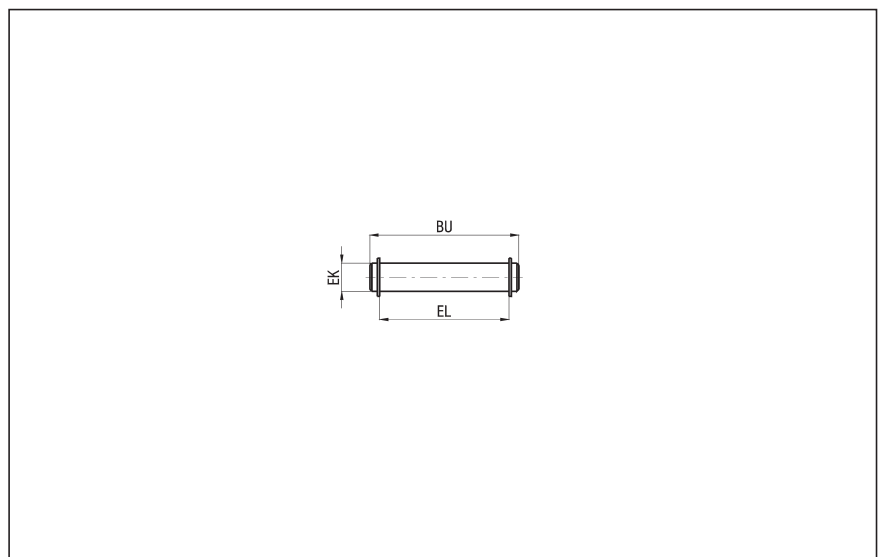

1

### NORMAL ARTICULATED JOINT - ALUMINIUM - CX/AN Ø

Ø	A	B	D	E	F	H	LY
32	25	0	40	28	7	26	123
40	32	16	52	38	9	38	168
50	32	16	52	38	9	38	170
63	46	25	75	54	11	52	194
80	46	25	75	54	11	52	196
100	56	32	115	90	14	61	229
125	56	32	115	90	14	61	233
160	71	43	180	150	18	80	285
200	71	43	180	150	18	80	285

Ø	P	S H9	T	WEIGHT (g)
32	18	8	8	26
40	26	12	10	56
50	26	12	10	56
63	34	16	12	176
80	34	16	12	176
100	41	20	16	376
125	41	20	16	376
160	55	25	20	924
200	55	25	20	924

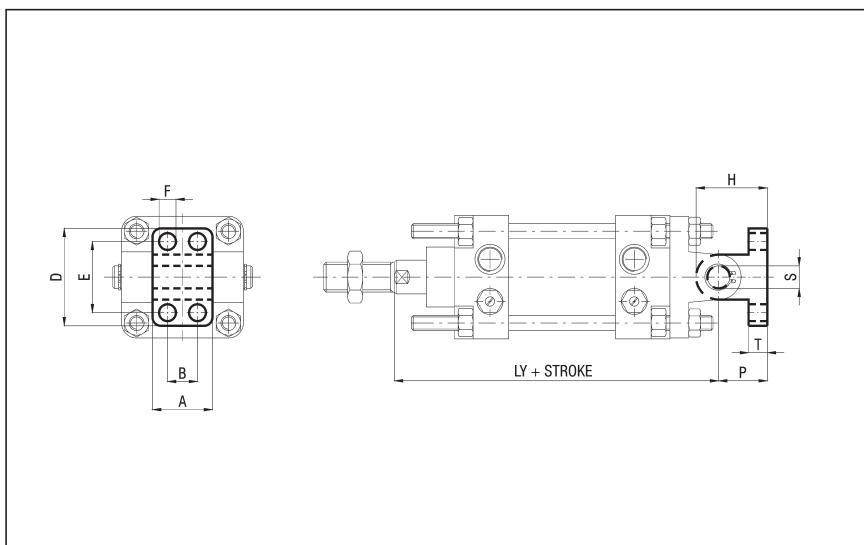

### SQUARE JOINT - ALUMINIUM - CX/AS Ø/SQ

Ø	A	B	BG	D	F H13	H	LY
32	25	25	20	37	7	18	123
40	32	32	32	54	9	25	168
50	32	32	32	54	9	25	170
63	46	40	50	75	11	32	194
80	46	40	50	75	11	32	196
100	56	50	70	103	14	40	229
125	56	50	70	103	14	40	233
160	70	63	110	154	18	50	285
200	70	63	110	154	18	50	285

Ø	P	R	S H9	T	V	WEIGHT (g)
32	32	19,5	8	8	41	58
40	45	26	12	10	52	144
50	45	26	12	10	52	144
63	63	32	16	13	63	300
80	63	32	16	13	63	300
100	90	42	20	17	80	649
125	90	42	20	17	80	649
160	140	54	25	20	111	1922
200	140	54	25	20	111	1922

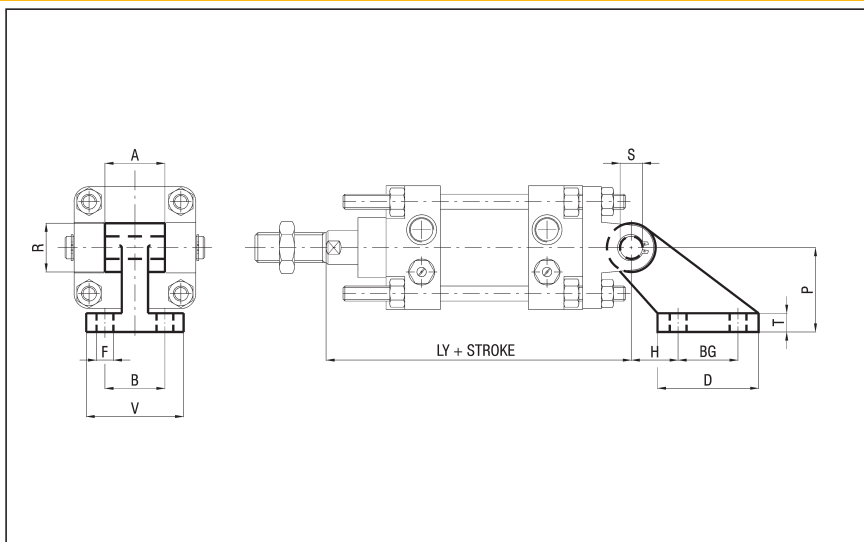

### INTERMEDIATE HINGE - Ø 32 ÷ 100 - STEEL - CX/CPU/CT Ø (Supplied with dowels) - Ø 125 ÷ 200 - STEEL - CX/CPII/CT Ø

Ø	A	B h14	D e9	E h14	G	M	Q min
32	46	50	12	12	15	6,25	58,5
40	59	63	16	16	20	6,25	73
50	69	73	16	16	20	8,25	73
63	84	90	20	20	25	8,25	85,5
80	102	108	20	20	25	10,25	86,5
100	125	131	25	25	30	10,25	101
125	155	160	25	25	32	12,25	105
160	190	200	32	32	40	16,25	120
200	240	250	32	32	40	16,25	120

Ø	Q max	WEIGHT (g)
32	71,5	130
40	105	306
50	105	370
63	117,5	702
80	116,5	894
100	138	1590
125	134	2600
160	160	4300
200	160	7450

P.S.:  
- ADJUSTABLE POSITION (fixing through dowels)  
**ASSEMBLY:**  
CX/CPU/CT Ø + cylinder CX type M/CX/CPU/CT Ø  
- FIXED POSITION  
(specify dimension "Q"; fixed on cylinder with completed threaded and galvanized tie rods type "S6", see on page 0.12)  
**ASSEMBLY:**  
CX/CPII/CT Ø or CX/CPII/CT Ø  
+ cylinder CX S6 type MF/CX/CPII/CT Ø

