

“Clean profile” cylinders to ISO 15552 standard

series X

DESCRIPTION

Pneumatic cylinders series “X” comply with ISO 15552 standard, being in this way completely interchangeable with the well-known cylinders to ISO 6431 standard, defining the dimensions of both the “nude” cylinder than assembled with fixings. They’re available in the bores from Ø 32 to Ø 100 and the cylinder barrel, made in extruded aluminium alloy, has some pits (“T”-shaped slots) on three sides where it’s possible to mount directly the new magnetic sensors series FM100. This peculiarity allows to leave the dimensions of the cylinders unchanged, keeping the mentioned sensors, completely embedded and granting them a better protection. The dynamic seals are made in high performances polyurethane with standard working temperature between -35°C and +80°C. Among all the available versions, a special mention deserves the non-rotating piston rod one with a particular section, made of AISI 304 stainless steel supplied as standard. The compact and advanced design makes the series “X” a product aesthetically appealing yet useful. In fact, thanks to proper cover strips that give the cylinders a really “clean profile”, the cylinders are not subject to receive dirt and so they result suitable also for “difficult” environments like the food one. A further feature is the possibility to assemble some series of valves directly on the cylinder barrel thanks to the brackets type “X/P/M..” (see page 1.24).



1

MATERIALS

End caps	Painted die-cast aluminium alloy
Cylinder barrel	Extruded profile, 20 µm anodized aluminium alloy
Screws	Steel (self-forming)
Piston rod	C45 chromium-plated steel AISI 303 rolled stainless steel
Rod nut	Steel Stainless steel
Piston rod bearing	Bronze-iron 20%, sintered, self-lubricating
Piston	Techno-polymer (supplied with and without magnet) Aluminium alloy for high temperatures
Seals	Polyurethane Viton®
Cover strips	Polyvinyl chloride

TECHNICAL DATA

Operating pressure	1 ÷ 10 bar
Working temperature	0 ÷ +80°C (with dry air -35°C) 0 ÷ +150°C with seals for high temperature (with dry air -10°C)
Fluid	Filtered, unlubricated or continuous lubricated compressed air
Versions	Double acting; Single acting front spring; Single acting rear spring; Through rod; Double push tandem; Double stroke tandem; Opposed tandem
Bore	Ø 32, 40, 50, 63, 80, 100
Port size	Ø 32 = G 1/8 Ø 40 - 50 = G 1/4 Ø 63 - 80 = G 3/8 Ø 100 = G 1/2
Standard strokes (mm)	25, 50, 75, 80, 100, 125, 150, 160, 200, 250, 300, 400 320, 350, 500, 550, 600, 650, 700, 800, 900, 1000
Decelerators lenght	Ø 32 40 50 60 80 100 mm 24 29 29 35 35 40
Maximum stroke (mm)	Ø 32 ÷ 100 = 3000
Max. stroke single acting (mm)	Ø 32 ÷ 100 = 50

ORDER KEY

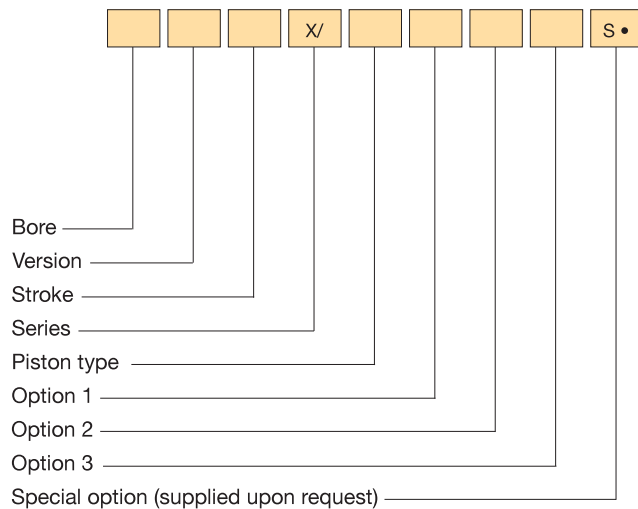

P.S.: Magnetic sensors FM100-FM157-FM158 (see chapter magnetic sensors from page 1.93)
• See technical data on page 0.12

ORDER EXAMPLES

Cylinder Ø 50, double acting, 100 mm stroke, non-magnetic piston type, fit for piston rod locking unit 50/100 X/NZ

Cylinder Ø 63, through rod, 150 mm stroke, magnetic piston type, stainless steel piston rod with cover strips 63R150 X/M14

Cylinder Ø 80, double stroke tandem, 50 mm stroke 1 + 100 mm stroke 2, magnetic piston type 80P50+100 X/M

VERSION

/ Double acting	T Double push tandem
S Single acting front spring	P Double stroke tandem
Y Single acting rear spring	V Opposed tandem
R Through rod	

PISTON TYPE

N Non-magnetic	M Magnetic
----------------	------------

OPTION 1

Z Fit for piston rod locking unit	A Stainless steel non-rotating piston rod
-----------------------------------	---

OPTION 2

1 Stainless steel piston rod and rod nut*	3 Stainless steel piston rod and rod nut and seals for high temperatures**
2 Seals for high temperatures**	

OPTION 3

4 Cover strips for magnetic sensors slots***
--

* Supplied as standard with option “A” (non-rotating piston rod)
** Supplied only with non-magnetic piston type and standard piston rod
*** Supplied as standard for big slot

SPARE PARTS

SEALS KIT	
Polyurethane	Ø/SG/X
Through rod polyurethane	Ø/SG/R/X
For high temperatures	Ø/SG/X2
Through rod for high temperatures	Ø/SG/R/X2

1

X BASIC CYLINDER

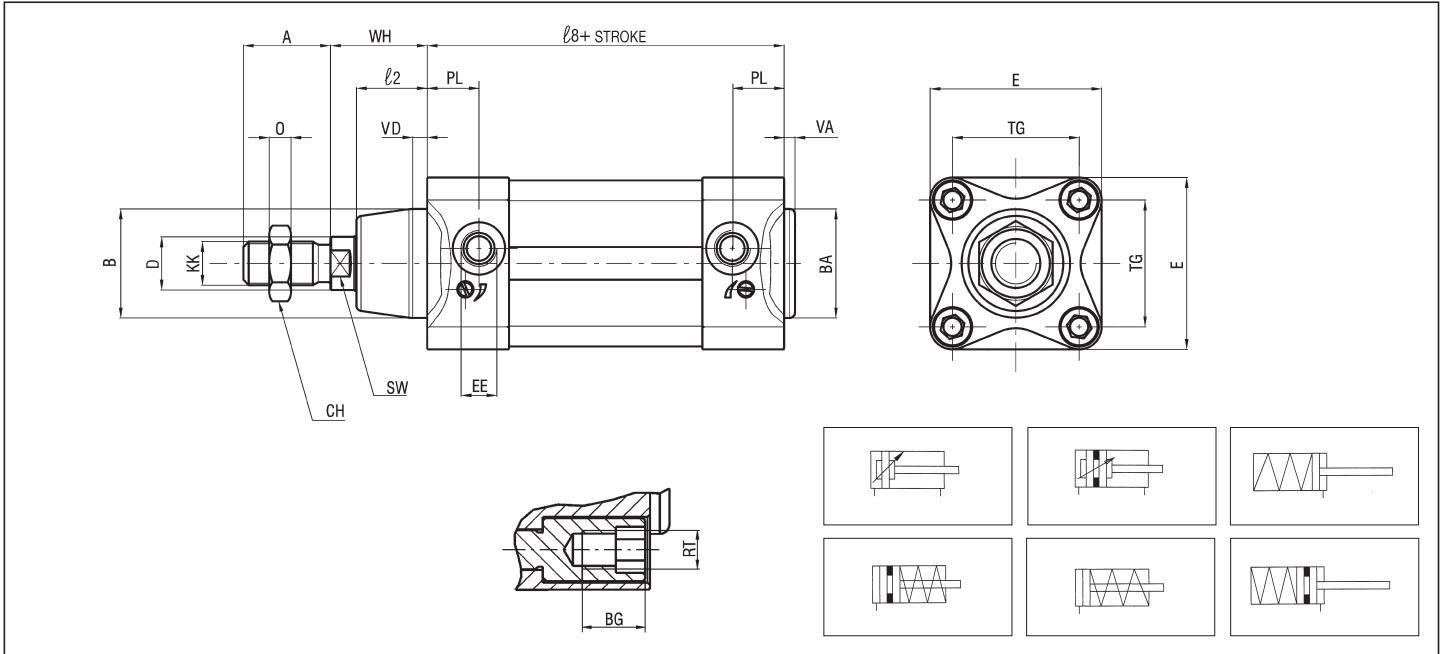

P.S.: Rod nut supplied as standard

DIMENSIONS AND WEIGHTS BASIC CYLINDER

Ø	A*	BA* B*	BG*	CH	RT*	E*	EE*	G	D	KK*	l	l2*	l8*	O	PL*	R	SW*	TG*	VA*	WB	WH*	WEIGHT (g)	INCR. (g) every 10 mm
32	22	30	16	17	M6	47	G1/8	27	12	M10x1,25	160	20	94	6	18	9	10	32,5	3	86	26	690	30
40	24	35	16	19	M6	52	G1/4	31	16	M12x1,25	185	22	105	7	20,5	9	13	38	3	100	30	900	45
50	32	40	16	24	M8	63	G1/4	30	20	M16x1,5	172	26	106	8	19	9	17	46,5	3	127	37	1240	60
63	32	45	16	24	M8	75	G3/8	35,5	20	M16x1,5	197	27	121	8	22	9	17	56,5	4	127	37	1750	80
80	40	45	16	30	M10	93	G3/8	36	25	M20x1,5	216	29	128	9	23	9	22	72	4	156	46	3580	100
100	40	55	16	30	M10	113	G1/2	39	25	M20x1,5	234	35	138	9	24	9	22	89	4	161	51	5270	120

* STANDARDIZED DIMENSIONS

THROUGH ROD

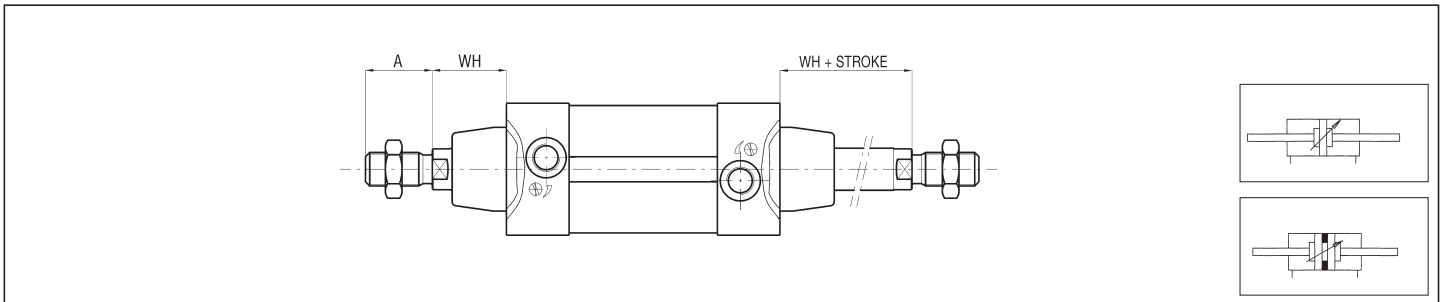

P.S.: Rod nuts supplied as standard

NON-ROTATING PISTON ROD

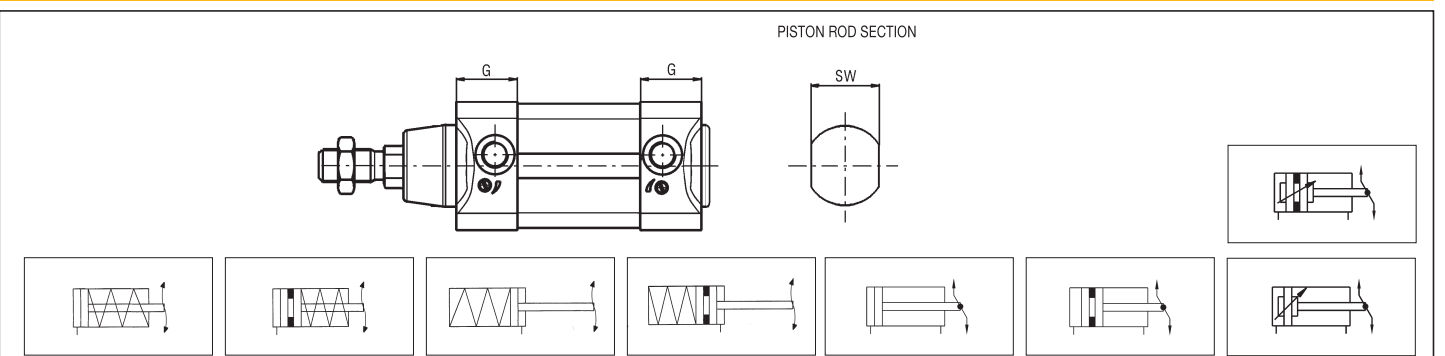

P.S.: Rod nut supplied as standard

DOUBLE PUSH TANDEM

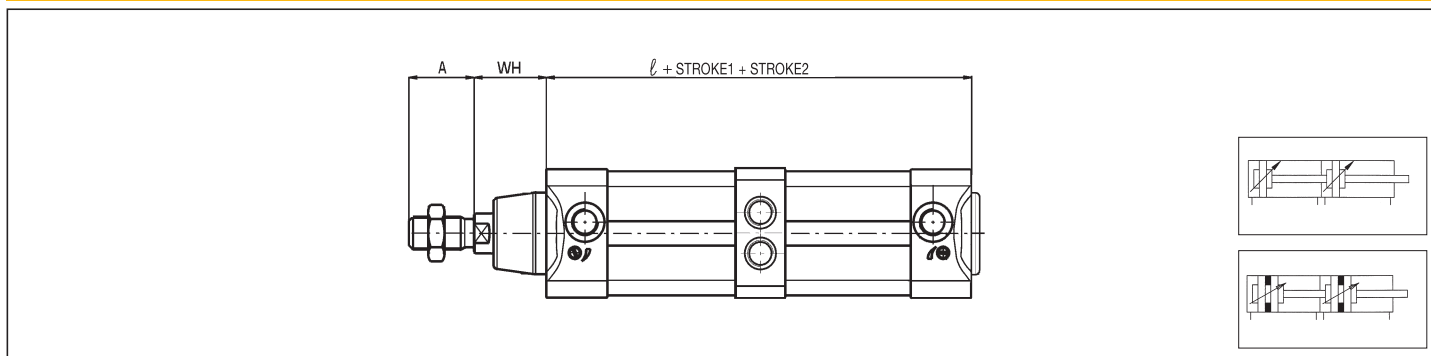

P.S.: Rod nut supplied as standard

DOUBLE STROKE TANDEM

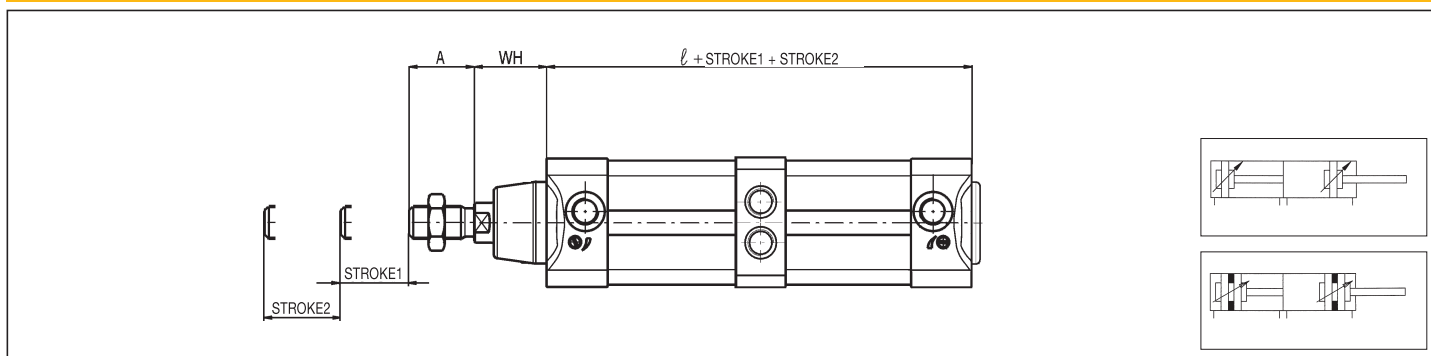

P.S.: Rod nut supplied as standard

OPPOSED TANDEM

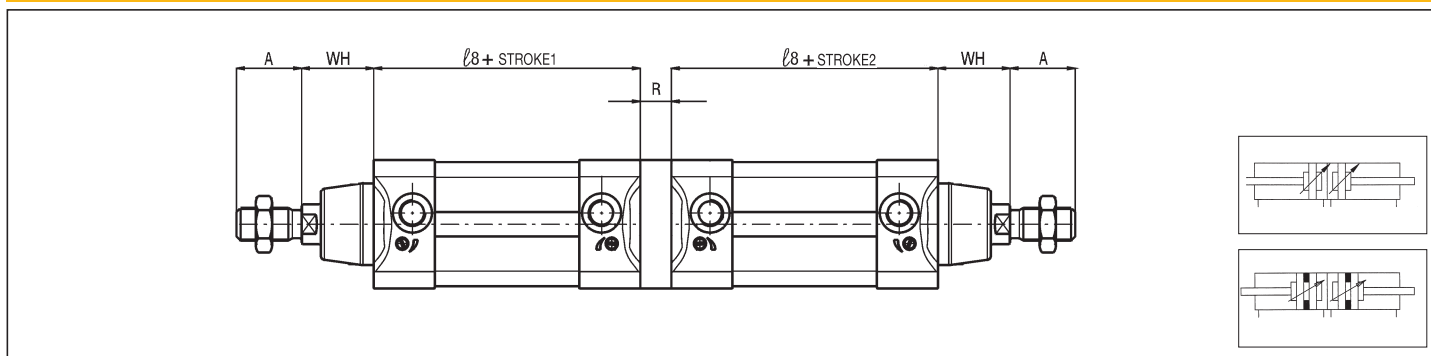

P.S.: Rod nuts supplied as standard

FIT FOR PISTON ROD LOCKING UNIT

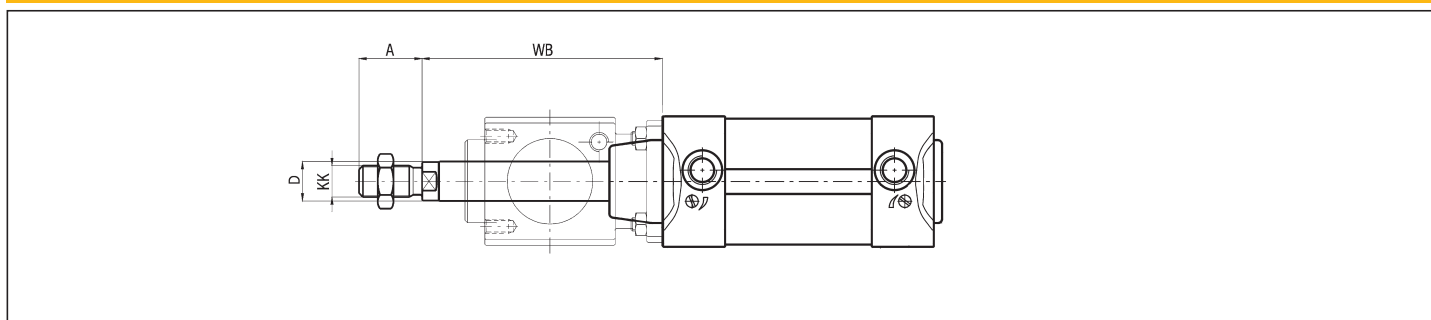

P.S.: Rod nut supplied as standard

1

SMALL SLOT COVER STRIP - X/CP

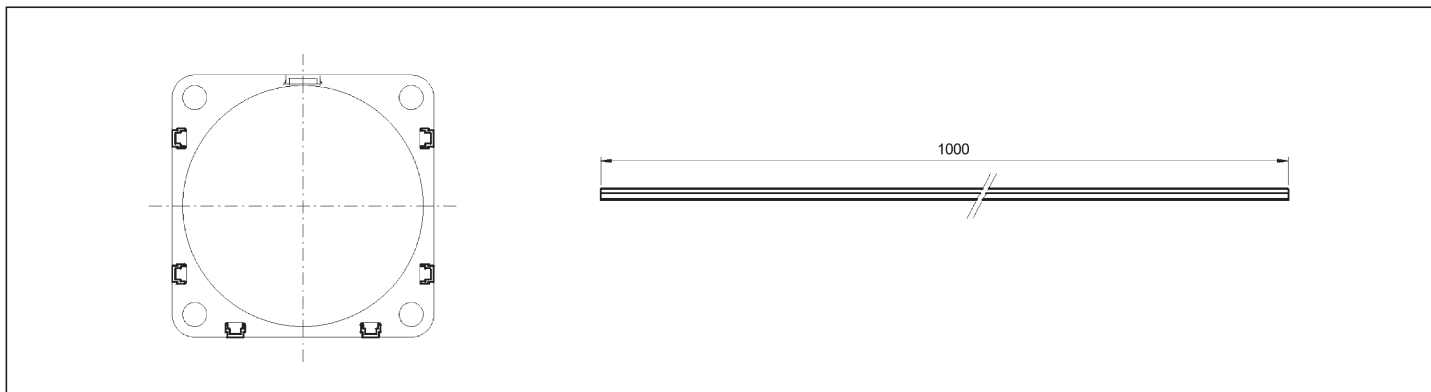

BIG SLOT COVER STRIP - X/CG

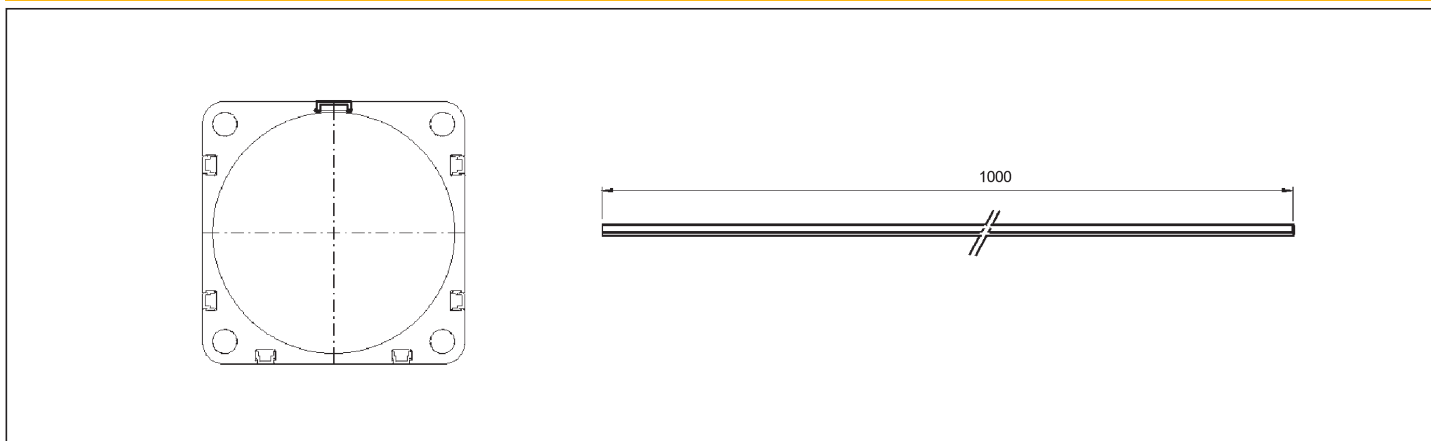

FIXING BRACKETS FOR “T” SLOTS - X/P/M..

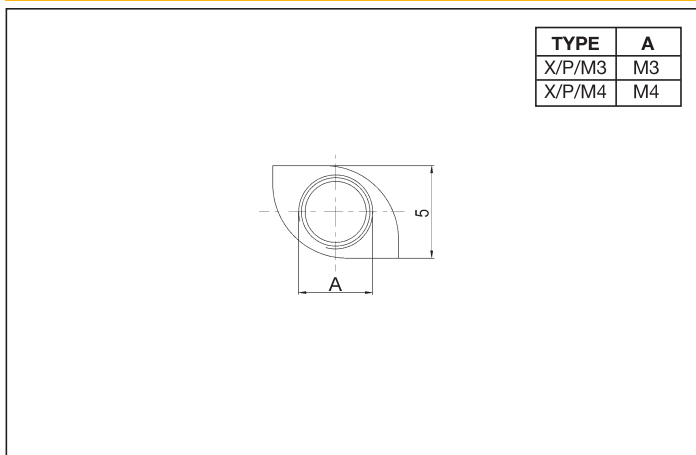

EXAMPLE OF ASSEMBLING OF VALVES MEV-MEK/CYLINDER

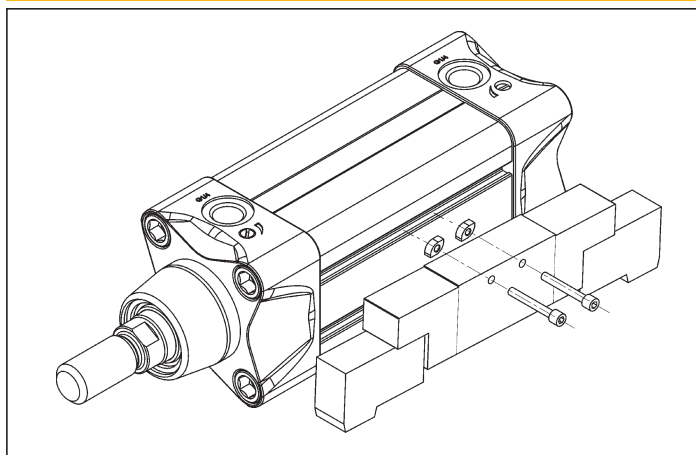

TECHNICAL INFORMATION FIXING BRACKETS

These brackets, with vertical insertion, allow to assembling directly on the cylinder barrel some series of valves and can be used even as reference point for the replacement of magnetic sensors.