

DESCRIPTION

Soft - start valves series "EZAP" are produced with connections G 3/8, G 1/2 and G 1 in the pneumatic and solenoid actuated versions. The working of the soft-start valves consists in feeding gradually air into the circuit with adjustable flow. When the pressure in the circuit reaches the 50 ÷ 60% of the upstream set pressure, the valve switches to full capacity, supplying the circuit with the maximum flow rate.

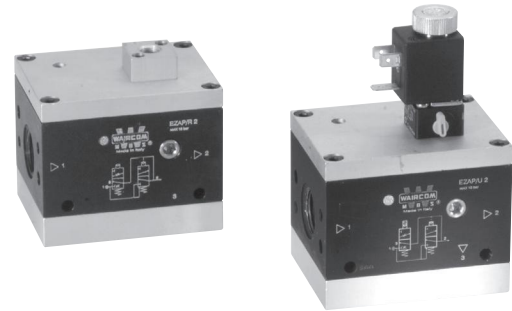

TECHNICAL DATA

Maximum pressure	10 bar
Working temperature	0 ÷ +50 °C (-10°C with dry air)
Fluid	Filtered, unlubricated or continuous lubricated compressed air
Port size	G 3/8 - G 1/2 - G 1
Flow rate at 6 bar ΔP=1 bar	G 3/8 = 1000 NI/min G 1/2 = 1650 NI/min G 1 = 4000 NI/min
Max. flow rate of the adjusting screw of the filling time	G 3/8 = 400 NI/min G 1/2 = 500 NI/min G 1 = 500 NI/min
Type of mounting	Modular, in-line and wall-mounting
Wall clamping screws	G 3/8: M4x60 G 1/2: M5x70 G 1: M6x90
Piloting solenoid valve	C/USCSVP - see chapter Direct acting solenoid valves on page 2.11
Coil	USB - see chapter Coils on page 2.14
Electric connector	USR 102/N9 - see chapter Connectors on page 2.15

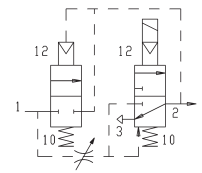
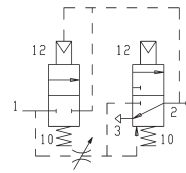

MATERIALS

Body	Aluminium alloy
Springs	Stainless steel
Pistons	Aluminium alloy
Seals	NBR rubber

ORDER KEY

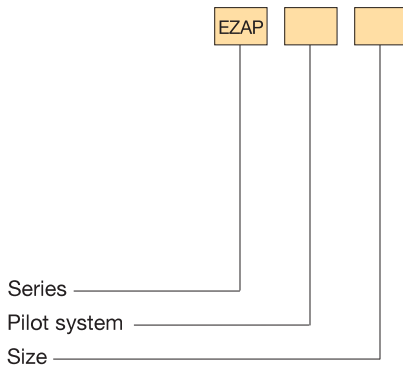

PILOT SYSTEM

/R Pneumatic /U Solenoid

SIZE

3 G 3/8 2 G 1/2
1 G 1

DIMENSIONS AND WEIGHTS EZAP /R

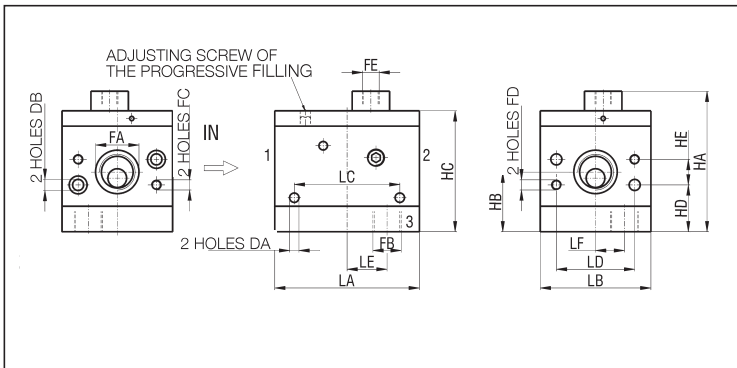

SIZE	DA	DB	FA	FB	FC	FD	FE	HA	HB	HC
3	4,5	5,1	G 3/8	G 1/8	-	M6	G 1/8	68	28,8	56,5
2	5,5	6,5	G 1/2	G 3/8	M6	M6	G 1/8	82,5	35	71

SIZE	HD	HE	LA	LB	LC	LD	LE	LF	WEIGHT (g)
3	28,8	-	70	50	51,5	35	20	12	505
2	27,5	15	85	65	62	46	23,5	17	985

DIMENSIONS AND WEIGHTS EZAP /U

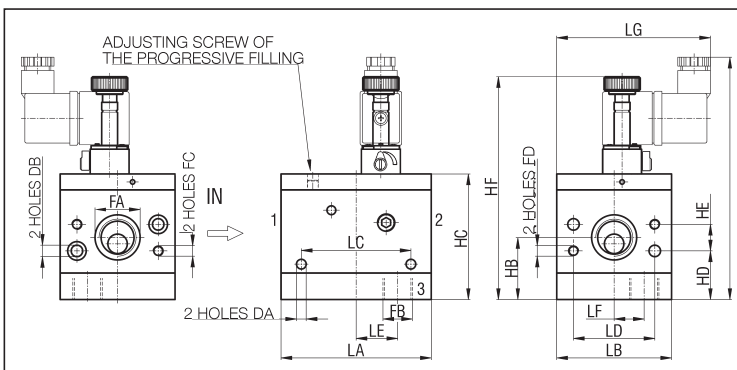

SIZE	DA	DB	FA	FB	FC	FD	HA	HB	HC	HD
3	4,5	5,1	G 3/8	G 1/8	-	M6	122,5	28,8	56,5	28,8
2	5,5	6,5	G 1/2	G 3/8	M6	M6	137	35	71	27,5

SIZE	HE	HF	LA	LB	LC	LD	LE	LF	LG	WEIGHT (g)
3	-	115,5	70	50	51,5	35	20	12	79,5	540
2	15	126	85	65	62	46	23,5	17	87	1020

DIMENSIONS AND WEIGHTS EZAP /R1

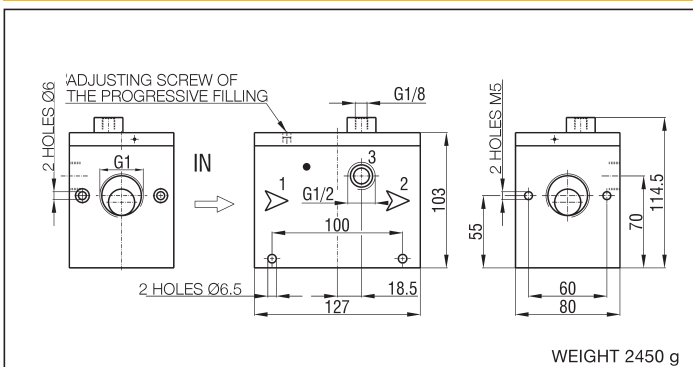

WEIGHT 2450 g

DIMENSIONS AND WEIGHTS EZAP /U1

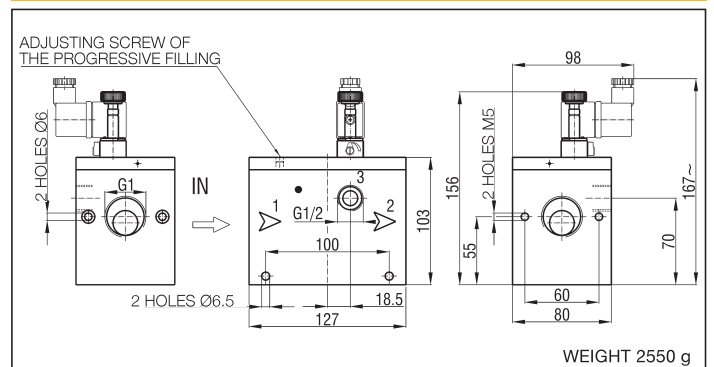

WEIGHT 2550 g